

Standard: plugged
Optional: water level detector
or sight glass

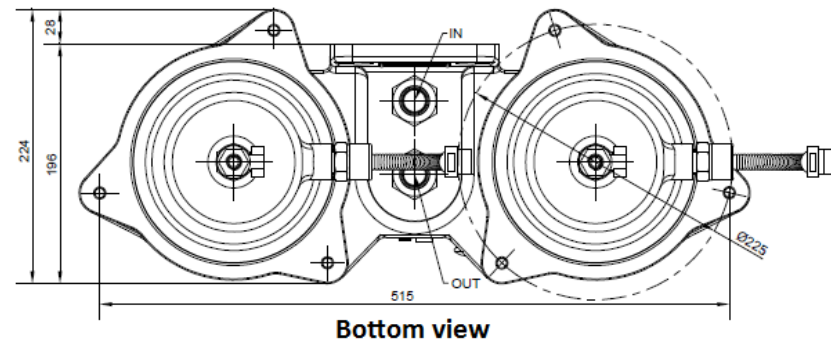

Dimensions in mm

DFBO
Dimensional drawing

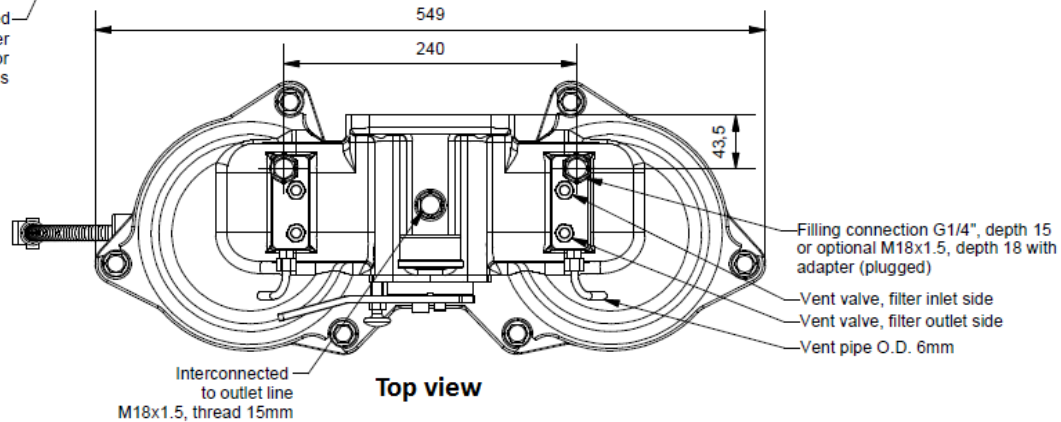